

CUSTOMER DRAWING

©2008 CARCLO
ALL DIMENSIONS IN mm

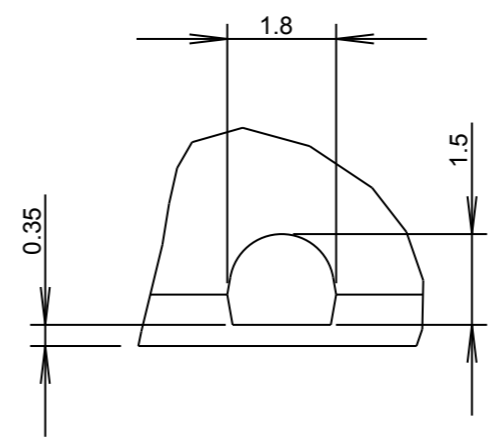
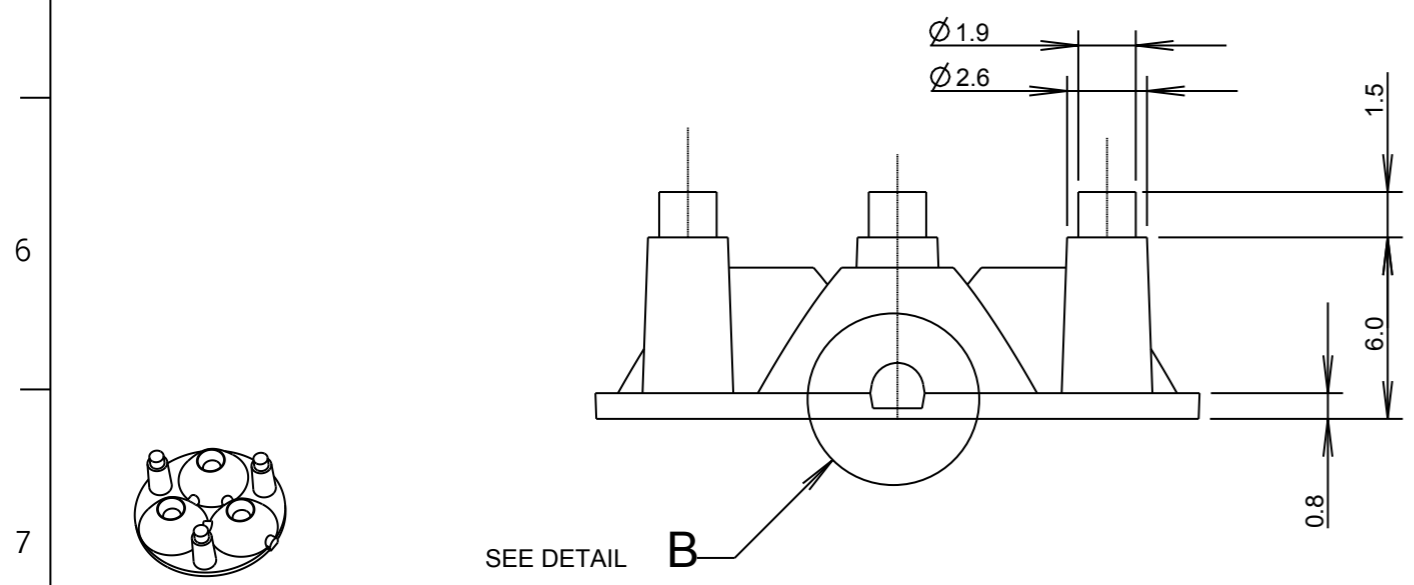
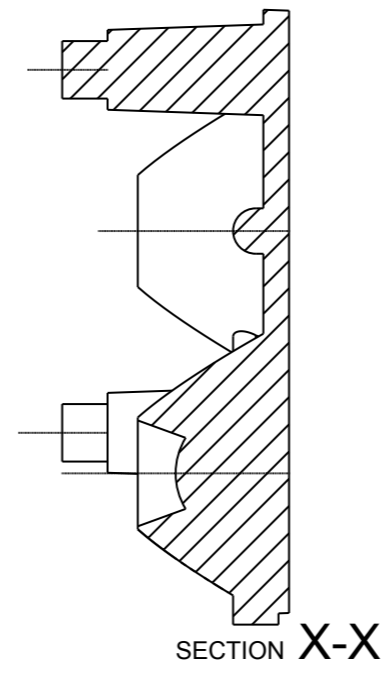

DETAIL B
SCALE 8:1

MATERIAL - UV STABILISED CLEAR POLYCARBONATE

ISS.	DATE	E.C.N.	DESCRIPTION
1	29-Apr-08		FIRST ISSUE
2	18-Jun-08		GATE SIZE INCREASED
3	12-Nov-08	10/08/1233	LEG PIN LENGTH REDUCED TO 15MM



CARCLO TECHNICAL PLASTICS (SLOUGH)
111 BUCKINGHAM AVE, SLOUGH
SL1 4PF, ENGLAND
TEL: +44 1753 575011 FAX: +44 1753 811359
email: design@carclo-optics.com

GENERAL TOLERANCES (UNLESS STATED)

LINEAR	ANGULAR
X +/- 0.25	X +/- 1°
X.X +/- 0.1	X.X +/- 0.5°
X.XX +/- 0.05	X.XX +/- 0.1°

CUSTOMER
CARCLO

TITLE
10mm TRIPLE OPTIC
WIDE FROSTED

DRAWN M.K. DATE 29-Apr-08

CHK'D DATE

APP'D DATE

SCALE 4:1 CARCLO PART No. 10509

SIZE A3 CARCLO DRG. No. 60524 SHEET 1 OF 2

SCALE 1:1

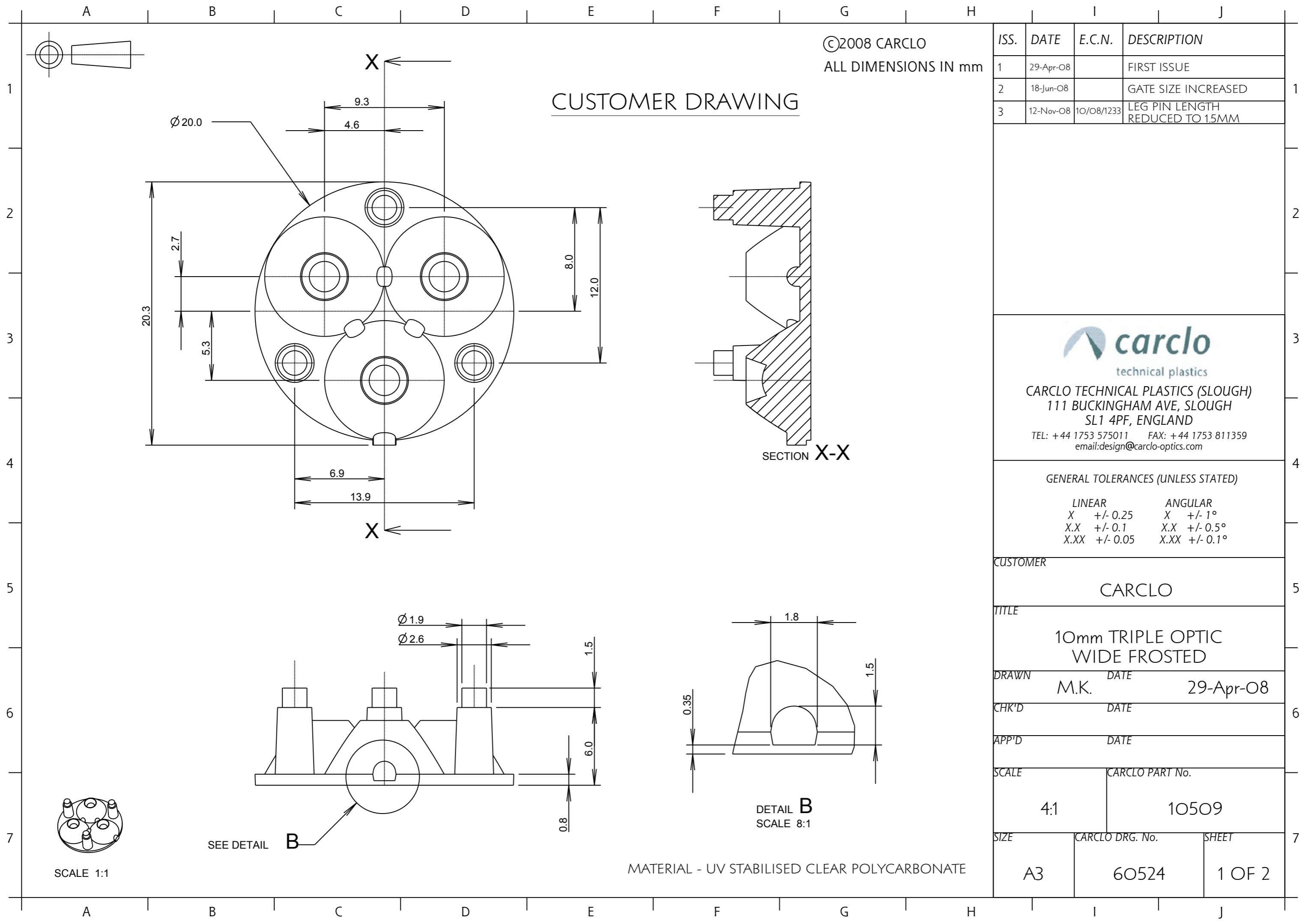

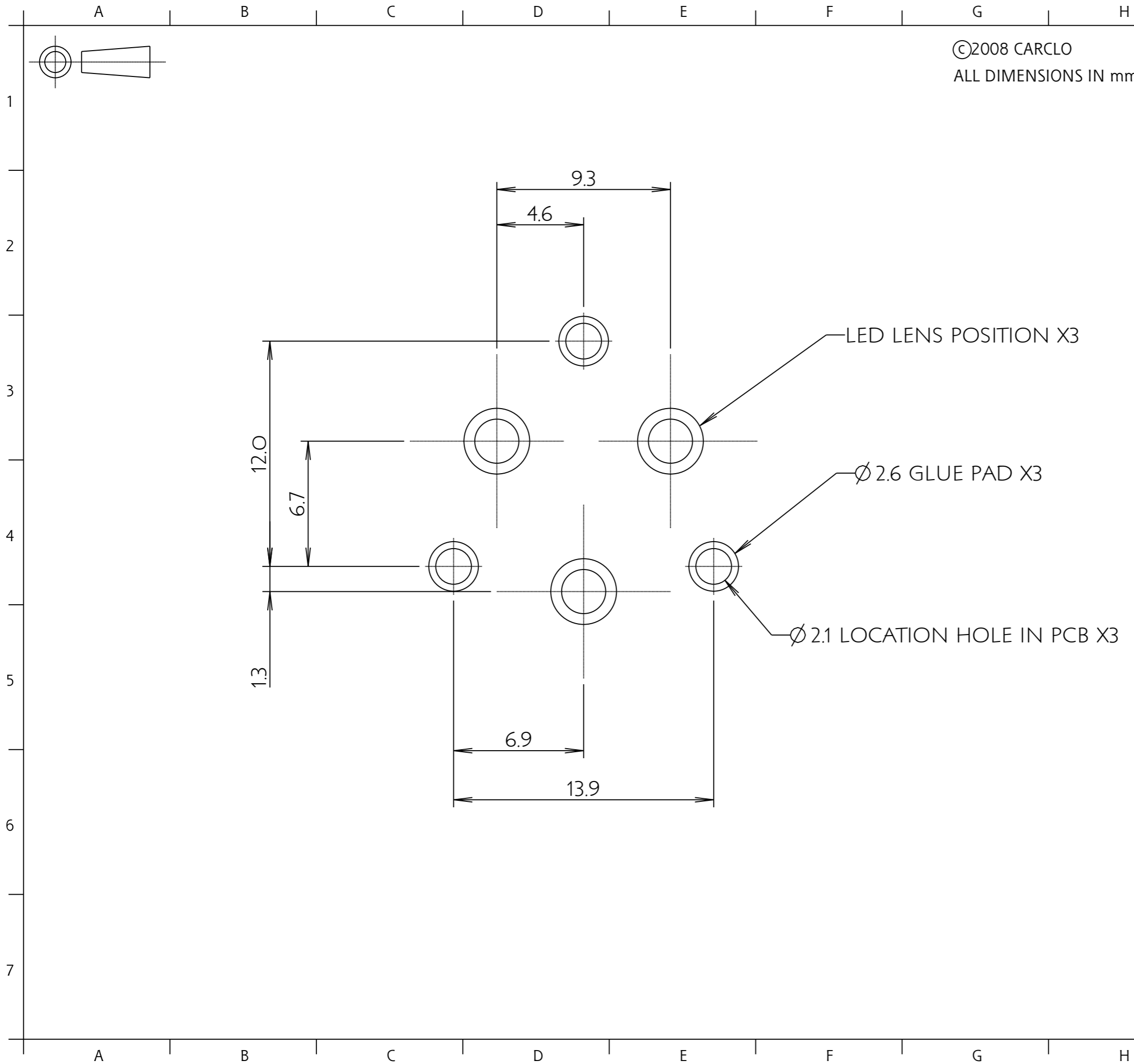

©2008 CARCLO
ALL DIMENSIONS IN mm

ISS.	DATE	E.C.N.	DESCRIPTION
1	06-May-08		FIRST ISSUE
2	18-Jun-08		GATE SIZE INCREASED
3	12-Nov-08	10/08/1233	LEG PIN LENGTH REDUCED TO 1.5MM

 technical plastics
CARCLO TECHNICAL PLASTICS (SLOUGH)
 111 BUCKINGHAM AVE, SLOUGH
 SL1 4PF, ENGLAND
 TEL: +44 1753 575011 FAX: +44 1753 811359
 email: design@carclo-optics.com

GENERAL TOLERANCES (UNLESS STATED)	
LINEAR	ANGULAR
X +/- 0.25	X +/- 1°
X.X +/- 0.1	X.X +/- 0.5°
X.XX +/- 0.05	X.XX +/- 0.1°

CUSTOMER
CARCLO

TITLE
**10mm TRIPLE OPTIC
WIDE FROSTED**

DRAWN M.K. DATE 06-May-08

CHK'D DATE

APP'D DATE

SCALE 5:1 CARCLO PART No. 10509

SIZE A3 CARCLO DRG. No. 60524 SHEET 2 OF 2